

*(This page intentionally left blank.)*

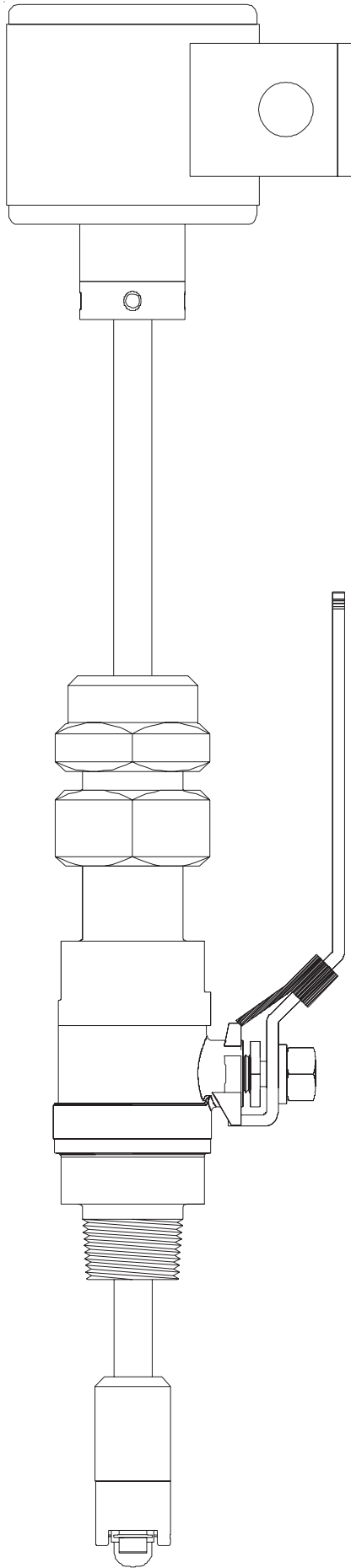

## Introduction

The Data Industrial SDI Series impeller flow sensor offers unparalleled performance for liquid flow measurement in closed pipe systems in an easy to install economical package. Impeller sensors offer a quick response to changes in flow rate and are well suited to flow control and batch type applications in addition to flow monitoring. The new four-bladed impeller design is rugged, non-fouling and does not require custom calibration.

Coupled with the proprietary patented digital detection circuit, the sensor measures flows from under 0.3 feet per second to over 20 fps regardless of the conductivity or turbidity of the liquid. The standard frequency output produces a low impedance square wave signal proportional to flow rate that may be transmitted up to 2000 feet without amplification. Models are available to measure flow in one or both directions.

All SDI insert sensors are mounted on the pipe using a 1" tap. As with any insert sensor, a pipe saddle or weld-on fitting is preferred over a service tee because it causes fewer disturbances to the flow.

## Models Available

**Direct insert sensor models** are installed in piping configurations that are not in service or under pressure.

**Hot tap insert sensor models** feature isolation valves and mounting hardware to install or remove the sensor from a pipeline that would be difficult to shut down or drain. In a true "hot tap" installation the sensor is mounted in the pipe under pressure by attaching a service saddle or weld-on fitting to the pipe and mounting the isolating valve and nipple to the threaded connection. A hole is then cut in the wall of the pipe through the valve using a commercial tapping machine with a 1" size cutter. Once the hole is cut, the tapping machine is removed and the valve is shut. Then the sensor assembly is mounted to the isolation valve and extended into the pipeline to measure flow.

Even in new construction a hot tap sensor may be appropriate for service considerations.

The small stem diameter allows the sensor to be inserted into the pressurized pipeline by hand without the need for an installation tool. The mounting hardware holds the sensor firmly in place at the

correct depth and alignment.

### Electronic Outputs

#### Standard Frequency

Sensor output is a pulse proportional to flow. The signal is similar to all 200 Series Data Industrial flow sensors and will interface with all existing Data Industrial transmitters and monitors. The power supply to the sensor and the output signal from the sensor is carried on the same two wires. Wire connections are made at screw terminals on removable headers inside the NEMA 4X housing.

#### Analog Output

The Sensor is also available with a two-wire loop powered 4-20 mA output. The analog output is produced by an on-board micro-controller for precise, drift-free signals. The unit is programmed from a computer using Windows® based software and a Data Industrial A-301 connection cable. Units may be pre-programmed at the factory or field programmed. All information is stored in non-volatile memory in the flow sensor.

#### Scaled Pulse Output

The scaled pulse is produced by an on-board micro-controller for precise, accurate outputs. This option may be programmed to produce an isolated dry contact closure scaled to any number of engineering units of measure. Sensors may be pre-programmed at the factory or field programmed using a Data Industrial A-301 connection cable and a Windows® based software program. All information is stored in non-volatile memory in the flow sensor. This is a four-wire option.

#### Bi-directional Flow- Analog Output

This option provides a programmable 4-20 mA signal proportional to flow rate and a contact closure to indicate the direction of flow. All programming is accomplished as previously mentioned. The user can program the unit for pipe size, flow scale and the direction of flow. This is a six-wire option.

#### Bi-directional Flow- Scaled Pulse Output

This option provides the user with a choice of outputs. In one case the sensor provides an output scaled to the required number of engineering units on one set of terminals and a contact closure to indicate the direction of flow on another. The other choice provides two isolated scaled pulse outputs, one for each direction. Programming the output choice, pipe size, output scale and direction of flow by the user are also accomplished by using a PC with Data Industrial software and A-301 connection cable. This option

**SDI Series Direct Insert Ordering Matrix**

	SDI	0	D1	N	0	0	-	0	2	0	0
<b>Material</b>											
Stainless Steel/PPS Tip		0									
Brass/PPS Tip		1									
Stainless Steel/PEEK Tip		2									
<b>Type</b>											
Direct Insert for Pipe 1-1/2" thru 10" *			D1								
Direct Insert for Pipe 12" thru 36" *			D2								
Direct Insert 36" and UP*			D3								
<b>Electronic Housing</b>											
NEMA 4X				N							
<b>Output</b>											
Standard Frequency Pulse		0									
Analog 4-20mA		1									
Scaled Pulse		2									
<b>Display</b>											
No Display		0									
LCD Option [not available with output option 0]		1									
<b>O-Ring</b>											
Viton®											0
<b>Shaft</b>											
Tungsten Carbide [Standard]											2
Hastelloy® C-276 [optional - consult factory]											1
Zirconia Ceramic [optional - consult factory]											0
<b>Impeller</b>											
Stainless Steel											0
<b>Bearing</b>											
Torlon®											0

\*Pipe size for reference only-Depending on pipe material, tapping saddle, or existing hardware, longer sensor length may be required. Consult Factory

**SDI Series Hot Tap Ordering Matrix**

	SDI	0	H1	N	0	0	-	0	2	0	0
<b>Material</b>											
Stainless Steel/PPS Tip		0									
Stainless Steel/PEEK Tip		2									
<b>Type</b>											
Hot Tap for Pipe 1-1/2" thru 10" *			H1								
Hot Tap for Pipe 12" thru 36" *			H2								
Hot Tap for Pipe 36" and UP*			H3								
<b>Electronic Housing</b>											
NEMA 4X				N							
<b>Output</b>											
Standard Frequency Pulse		0									
Analog 4-20mA		1									
Scaled Pulse		2									
Bi-Directional, 4-20mA + Direction [PPS tip Only]		5									
Bi-Directional, Scaled Pulse [PPS tip Only]		6									
<b>Display</b>											
No Display		0									
LCD Option [not available with output option 0]		1									
<b>O-Ring</b>											
Viton®											0
<b>Shaft</b>											
Tungsten Carbide [Standard]											2
Hastelloy® C-276 [optional - consult factory]											1
Zirconia Ceramic [optional - consult factory]											0
<b>Impeller</b>											
Stainless Steel											0
<b>Bearing</b>											
Torlon®											0

\*Pipe size for reference only-Depending on pipe material, tapping saddle, or existing hardware, longer sensor length may be required. Consult Factory

### Display Options-

All models except the standard frequency output version may also be equipped with a display. Integrated into the NEMA 4 housing, the 8 digit LCD may be programmed to show rate of flow, flow total or toggle between the two. Bi-directional models also show flow direction.

### Mechanical Installation

The accuracy of flow measurement for all insert type flow measuring devices is highly dependent on proper location of the sensor in the piping system. Irregular flow velocity profiles caused by valves, fittings, pipe bends, etc. can lead to inaccurate overall flow rate indications even though local flow velocity measurement may be accurate. A sensor located in the pipe that is partially full or where it can be affected by air bubbles, floating debris, or sediment may not achieve full accuracy and could be damaged.

Data Industrial flow sensors are designed to operate reliably under adverse conditions, but the following recommendations should be followed to ensure maximum system accuracy:

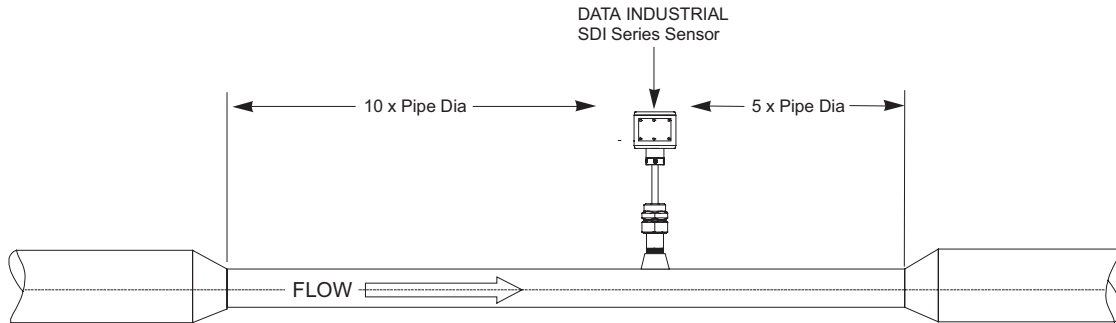

- 1) Choose a location along the pipe where there is straight pipe for a distance of 10 pipe diameters upstream and 5 pipe diameters downstream of the sensor. Pipe bends, valves, other fittings, pipe enlargements and reductions or anything else that would cause a flow disturbance should not be present in this length of pipe.
- 2) The recommended tap location around the circumference of a horizontal pipe is on top. If trapped air or debris will interfere, then the sensor should be located around the pipe from the top preferably not more than 45 degrees from top dead center. The sensor should never be located at the bottom of the pipe, as sediment may collect there. Locations off top dead center cause the impeller friction to increase, which may affect performance at low flow rates. Any circumferential location is correct for installation in vertical pipes.

- 3) Insertion depth is critical to accuracy. The algorithm used to convert impeller motion into flow was developed through flow tests in an independent calibration laboratory. The impeller must be located in the same position in the pipe as it was in the calibration test for the impeller frequency to accurately describe the same liquid velocity. Detailed installation instructions on the following pages include methods for ensuring correct insertion depth.
- 4) Alignment of the sensor is also important. The impeller shaft must be perpendicular to the flow for accuracy. Alignment instructions are also included on the following pages.

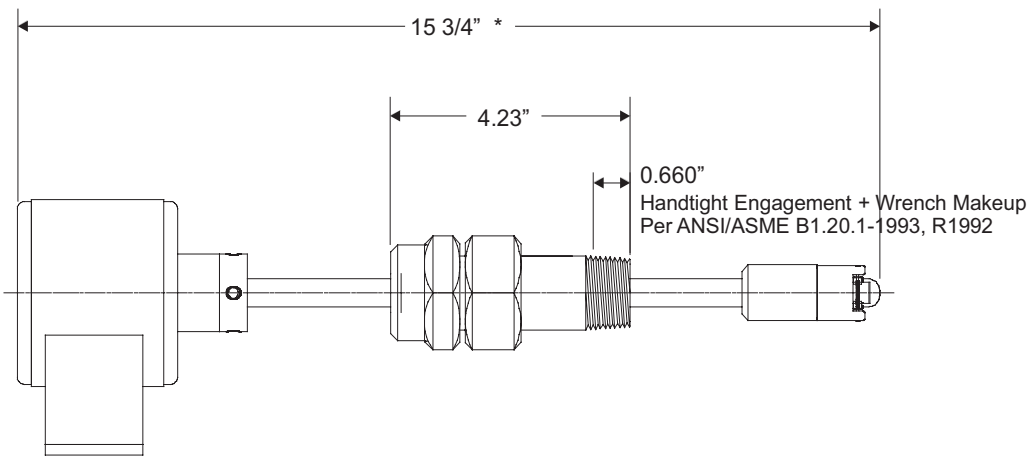

\* Pipe Sizes for reference only - Depending on pipe material, tapping saddle, or existing hardware longer sensor length may be required - Contact Factory.

also requires six wires.

**Installation for Direct insert models**

***These instructions are for the installation of flow sensors into piping systems that are not under pressure at the time of installation. If the line must be tapped under pressure, a hot tap style sensor must be used. See following section for hot tap installation instructions.***

The insertion depth and alignment of the sensor are critical to the accuracy of the flow measurement. The impeller must be at the same location in the pipe as it was during calibration. Data Industrial provides sensors with different stem lengths. Longer stems are intended for use in larger diameter pipes and shorter stems for use in smaller pipelines. However stem length has no affect on the operation of the sensor provided that the impeller is positioned correctly in the pipe.

Direct insert models are available in one stem length designated D1. They are intended for nominal pipe diameters from 1 1/2" to 10". However, pipe with extra thick walls, existing linings, or unusual tapping hardware may require longer length sensors - Consult factory. For larger pipe sizes hot tap style sensors equipped with an isolation valves are recommended.

The preferred method of installation is by means of a saddle with 1" NPT outlet. On steel pipelines a weld-on type fitting may be substituted.

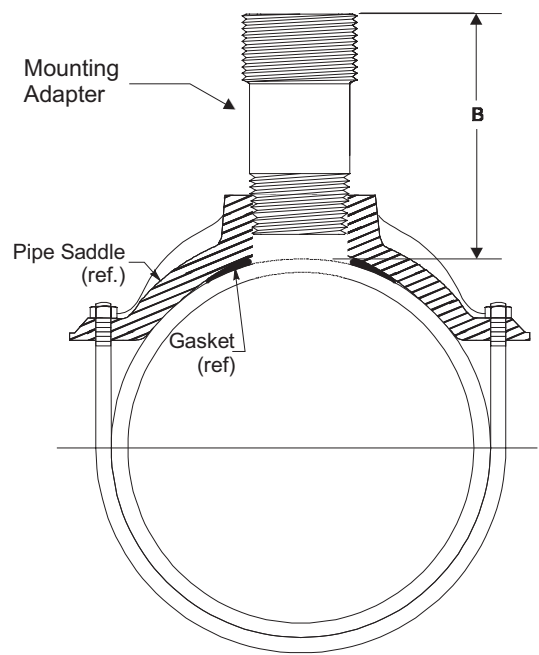

1. Attach the saddle to a section of pipe that has at least 10 diameters of straight pipe ahead and five diameters of straight pipe behind the saddle. Drill a minimum 1 1/8" diameter hole in the pipe.
2. Remove the sensor assembly from the mounting hardware by loosening the hex cap over the stem collar and the cover to the mounting adapter and detaching the assembly. Set aside taking care not to damage impeller/shaft assembly.
3. Attach the pipe thread end of the mounting adapter to the saddle/weld-o-let using a pipe joint compound and tighten the joint. *Do not apply sealing compound to the top thread of the mounting adapter. It is sealed with an o-ring.*
4. The sensor rotor assembly is to be located a fixed distance from the center of the pipe. To position the impeller at this depth, a reference measurement for the pipe size and schedule is used. Look up the pipe size and schedule number in **Table A** and note the reference number. Next, measure from the outside wall of the pipe to the top of the installed mounting adapter "B" in Figure 3. Add this number to the reference measurement.

The resulting number, "C" in Figure 4 is the distance from the recess of the sensor tip to the bottom of the stem collar. Insert the metal tab of a tape measure into the recess of the flow sensor tip. Extend the tape up the stem and mark the shaft with a pencil. Slide the collar along the shaft until its bottom surface is at the mark on the stem. Tighten the cap screw on the collar. When the sensor is reassembled, this will set the insertion depth of the sensor.

5. Attach the sensor to the mounting adapter by gently pushing the flow sensor into the mounting adapter until the cover touches the mounting adapter. Tighten the cover against the o-ring seal. This will seal the sensor assembly.
6. Continue to insert the flow sensor stem until the stem collar meets the cover. Thread the hex cap onto the mounting adapter but don't tighten. Align the flow sensor with the pipe by using the flat cover on the electronics housing as a guide. Place a straightedge along the cover and rotate the sensor until the straightedge is parallel with the pipe. Tighten the hex cap over the collar approximately 10 foot pounds. The hex cap holds the sensor alignment but performs no sealing functions. **DO NOT OVERTIGHTEN.**
7. Pressurize pipeline and check for leaks.

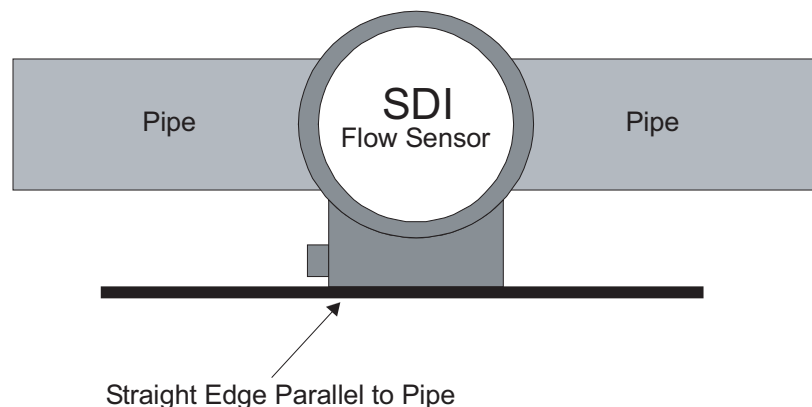
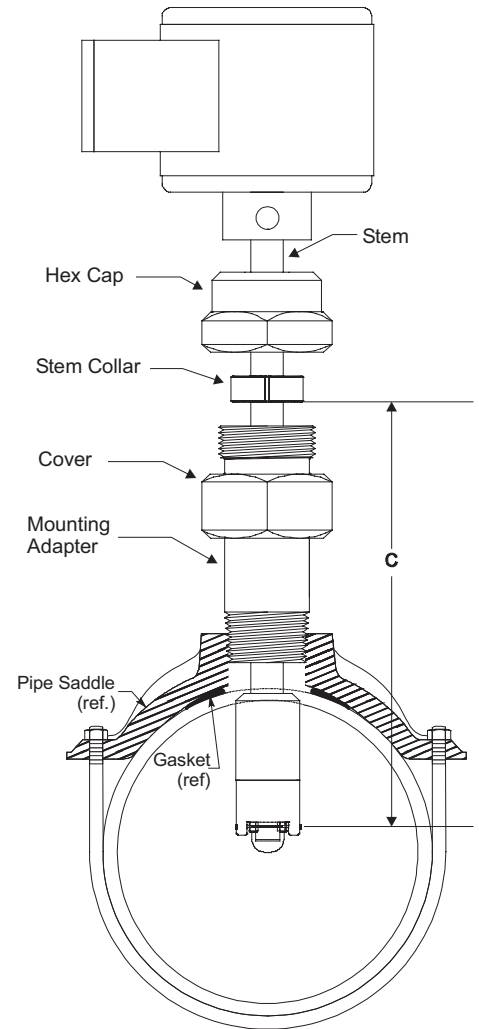

## Installation for Hot tap models

The insertion depth and alignment of the sensor are critical to the accuracy of the flow measurement. The impeller must be at the same location in the pipe as it was during calibration. Data Industrial provides sensors with three different stem lengths. Longer stems are intended for use in larger diameter pipes and shorter stems for use in smaller pipelines. However stem length has no effect on the operation of the sensor provided that the impeller is positioned correctly in the center of the pipe.

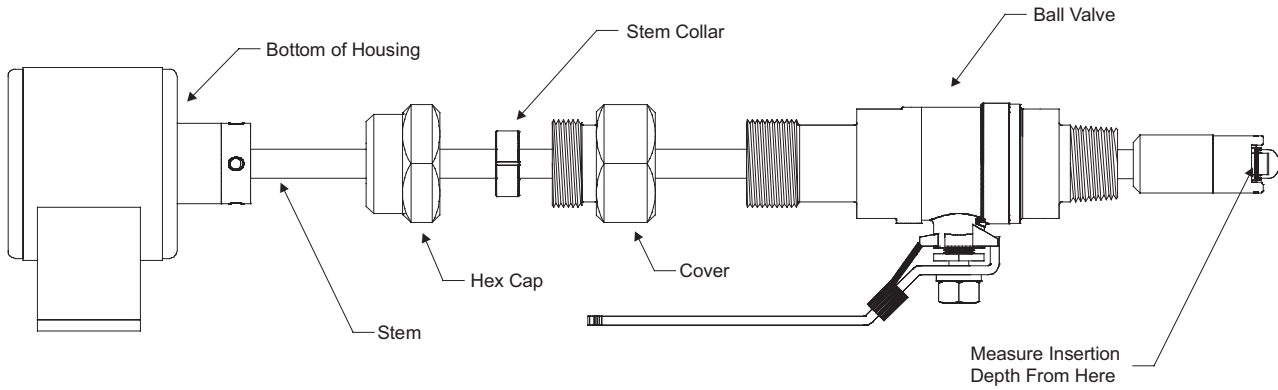

Stem length H1 is intended for use in nominal pipe diameters from 1 1/2" to 10", H2 is for nominal pipe diameters from 12" to 36", and stem length H3 is for nominal pipe diameters from 36" and up. However, pipe with extra thick walls, existing linings, or unusual tapping hardware may require longer length sensors - Consult factory.

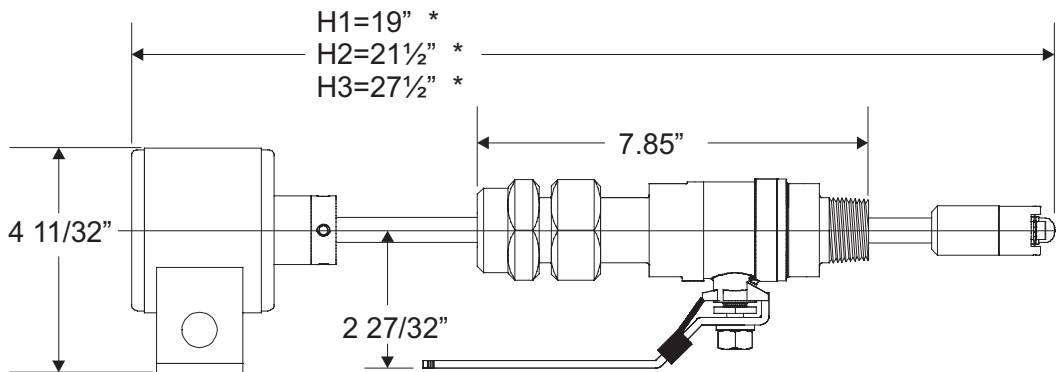
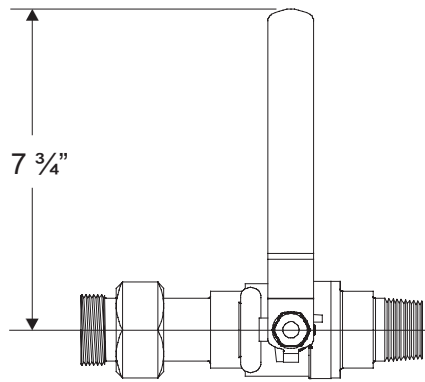

\* Pipe Sizes for reference only - Depending on pipe material, tapping saddle, or existing hardware longer sensor length may be required - Contact Factory.

The preferred method of installation is by means of a saddle with 1" NPT outlet. On steel pipelines a weld-on type fitting may be substituted.

1. Attach the saddle to a section of pipe that has at least 10 diameters of straight pipe ahead and five diameters of straight pipe behind the saddle.
2. Remove the sensor assembly from the mounting/isolation valve by loosening the hex cap over the stem collar and the cover to the mounting/isolation valve and detaching the assembly. Set aside taking care not to damage impeller/shaft assembly.
3. Attach the pipe thread end of the valve to the saddle using a pipe joint compound and tighten the joint. *Do not apply sealing compound to the top thread of the valve. It is sealed with an o-ring.*
4. Attach the tapping adapter, Data Industrial part number A-1027 to the top of the valve.
5. Any pipe tapping machine with a 1" pipe thread connection may be used. Use a cutter appropriate for the pipe material being tapped.

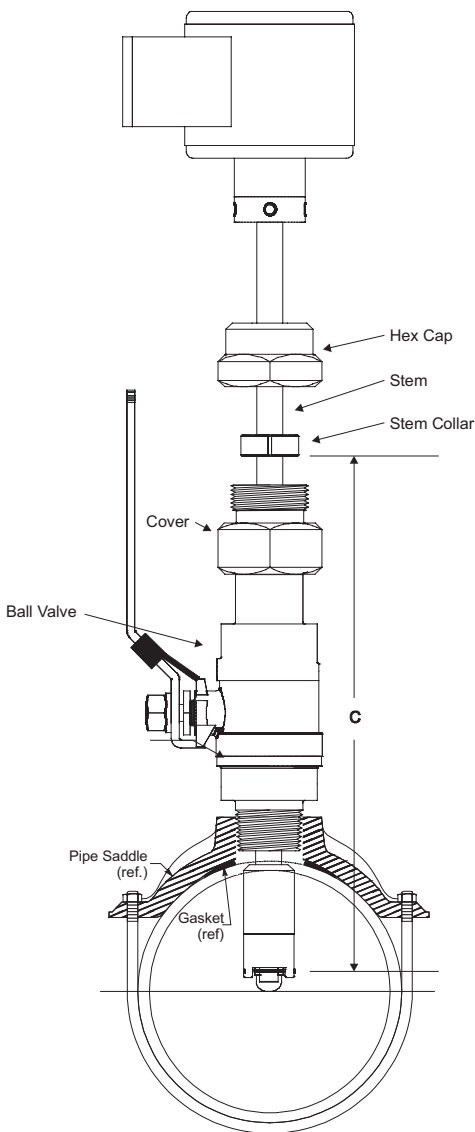
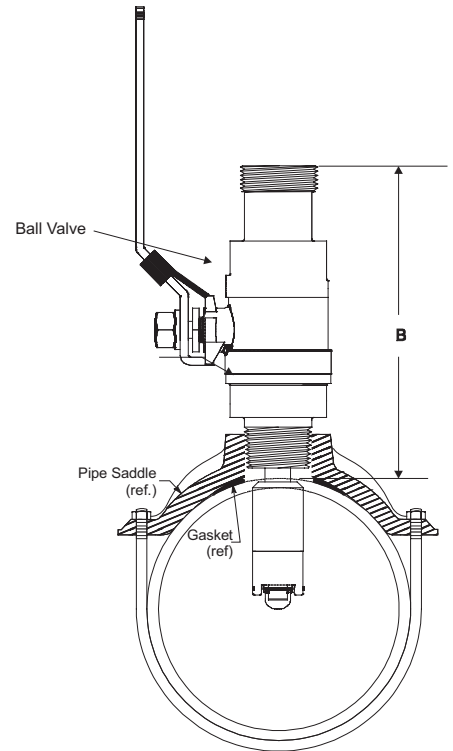

6. Attach the tapping machine to the tapping adapter. Ensure that all connections and seals are tight.
7. Slowly open the valve by rotating the handle 90° and lower the cutter past the valve ball to the pipe. Drill the 1" nominal hole according to the manufacturer's instructions. Withdraw the cutter past the valve ball, close the valve and remove the tapping tool.
8. Remove the Data Industrial tapping adapter from the top of the valve.
9. The sensor rotor assembly is to be located a fixed distance from the center of the pipe. To position the impeller at this depth, a reference measurement for the pipe size and schedule is used. Look up the pipe size and schedule number in **Table A** and note the reference number. Next, measure from the outside wall of the pipe to the top of the ball valve "B" in Figure 8. Add this number to the reference measurement.

The resulting number is the distance from the recess of the sensor tip to the bottom of the stem collar "C" in Figure 9. Insert the metal tab of a tape measure into the recess of the flow sensor tip. Extend the tape up the stem and mark the shaft with a pencil. Slide the collar along the shaft until its bottom surface is at the mark on the stem. Tighten the cap screw on the collar. When the sensor is reassembled, this will set the insertion depth of the sensor.

10. Slide the cover down the stem until it stops. Attach the sensor to the valve by inserting the impeller end of the stem into the valve until the cover touches the top of the valve. The sensor tip and impeller will be in the section of the valve above the ball. Tighten the cover against the o-ring in the top of the valve. This will seal the sensor assembly. Open the ball valve again by slowly rotating the handle 90°. If the cover was not at the bottom of the sensor stem, water pressure from the pipe would now push it out until it stops. However, the sensor cannot be ejected from the pipe if the cover is secured to the valve. Check to make sure all joints are tight.
11. Insert the flow sensor stem into the pipe by pushing against the top of the electronics housing with a slight twisting motion until the stem collar meets the cover. The force required to push the sensor into the pipeline is approximately 20% of the line pressure. Be aware of the close spacing between the diameter of the flow sensor, the bore of the ball valve and the hole in the pipe. If the sensor stops or “catches” before the stem collar meets the cover, apply a gentle rocking/twisting motion to the sensor to continue its travel. While holding the flow sensor collar against the cover, thread the hex cap onto the cover to hold the flow sensor in place but do not tighten. Align the flow sensor with the pipe by using the flat side cover of the electronics housing as a guide. Place a straightedge along the cover and rotate the sensor until the straightedge is parallel to the pipe. Tighten the hex cap to the cover to approximately 10 foot pounds. The hex cap holds the sensor alignment and depth but performs no sealing functions. *DO NOT OVERTIGHTEN.*
12. Pressurize pipeline and check for leaks.

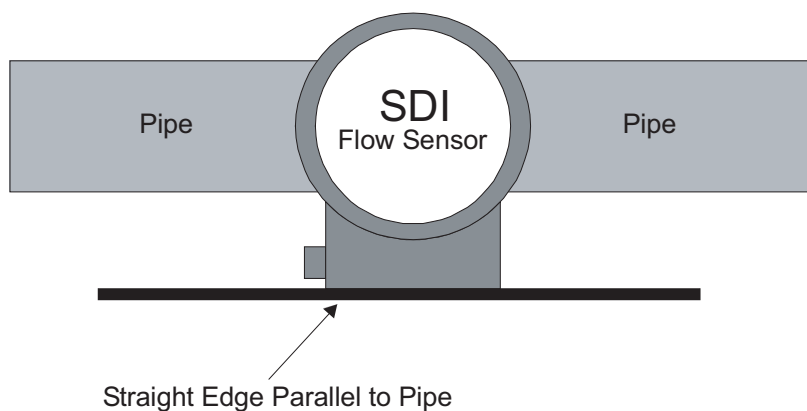

## Electrical Installation

Access wiring terminals by removing side cover. A wiring diagram is on the side cover, under the gasket. Use care when replacing side cover to insure that the gasket is in place.

**DO NOT REMOVE CIRCULAR COVER** from top of sensor. You may disturb seal and label alignment.

A moisture absorbing silica pack has been placed inside the electronics housing during assembly. Leave in place after making wire connections.

### Standard frequency (Pulse) output - Option “0” in the ordering matrix

This two wire sensor is intended for connection to Data Industrial monitors and transmitters or other devices that supply 10-24 DC excitation voltage and accept frequencies from 0 to 1000Hz.

Attach the sensor shield terminal 1 to the shield terminal on the transmitter (used for maximum protection from interference).

Attach the sensor common terminal 2 to the common (-) terminal on the transmitter.

Attach the sensor signal terminal 3 to the signal (+) terminal on the transmitter.

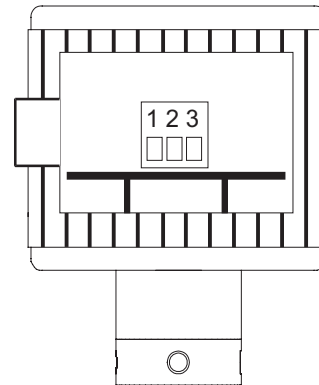

1. Shield
2. Sensor Common
3. Sensor Signal

### Analog 4-20mA Output - Option “1” in the ordering matrix

This option provides a programmable 4-20 mA signal proportional to flow rate. All programming is accomplished as previously mentioned. The user can program the unit for pipe size, flow scale. This is a two-wire option.

Attach **SDI #1 (Shield)** to Earth Ground or Power Supply Common. (This provides maximum power and signal EMI protection).

#### ANALOG OUTPUT – WIRED AS CURRENT SINKING

Attach **SDI#2 (Loop -)** to the Analog input terminal of device receiving this 4-20mA signal.

Attach **SDI#3 (Loop +)** to +24VDC terminal of device receiving the 4-20mA Signal.

#### ANALOG OUTPUT – WIRED AS CURRENT SOURCING – (WITH SEPARATE 24VDC POWER SUPPLY)

Attach **SDI#2 (Loop -)** to Analog input terminal of device receiving this 4-20mA signal. (Sometimes labeled Loop +).

Attach **SDI#3 (Loop +)** to +24VDC Supply terminal.

Attach -24VDC Supply terminal to the Analog Input Common. (Sometimes labeled Loop -).

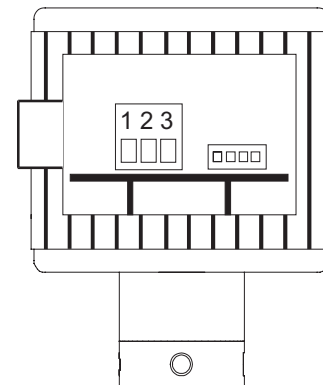

1. Shield
2. Loop -
3. Loop +

### Scaled Pulse output - Option “2” in the ordering matrix

This option provides a programmable opto-isolated solid state switch closure with internal solid state fuse protection. All programming is accomplished as previously mentioned. The user can program the unit for pipe size, flow scale and the direction of flow. This is a six-wire option.

Attach **SDI #1 (Shield)** to Earth Ground or Power Supply Common. (This provides maximum power and signal EMI protection).

Attach **SDI #2 (Power -)** to the negative terminal of a nominal 12-24VAC/VDC Power Supply. (See data sheet for current draw and voltage limits).

Attach **SDI#3 (Power +)** to positive terminal of power supply.

Attach **SDI #4 (Pulse -)** to the Input pulse (-) of the receiving device.

Attach **SDI #5 (Pulse +)** to the Input pulse (+) of the receiving device.

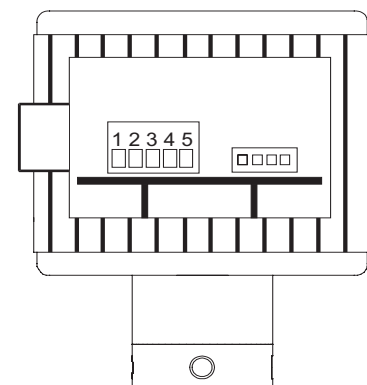

1. Shield
2. Power -
3. Power +
4. Pulse -
5. Pulse +

## Bi-Directional Analog Output - Option "5" in the ordering matrix

This option provides a programmable 4-20 mA signal proportional to flow rate and a contact closure to indicate the direction of flow. All programming is accomplished as previously mentioned. The user can program the unit for pipe size, flow scale and the direction of flow. This is a six-wire option.

Attach **SDI #1 (Shield)** to Earth Ground or Power Supply Common. (This provides maximum power and signal EMI protection).

Attach **SDI #2 (Power -)** to the negative terminal of a nominal 12-24VAC/VDC Power Supply. (See data sheet for current draw and voltage limits).

Attach **SDI#3 (Power +)** to positive terminal of power supply.

Attach **SDI #4 and SDI#5 (Direction +/-)** to the device receiving the directional signal. (This connection is not polarity sensitive; and, when active, provides a solid state switch closure for a maximum load of 100mA @30VAC or +/-40VDC).

### ANALOG OUTPUT – WIRED AS CURRENT SINKING

Attach **SDI#6 (Loop -)** to the Analog input terminal of device receiving this 4-20mA signal.

Attach **SDI#7 (Loop +)** to +24VDC terminal of device receiving the 4-20mA Signal.

### ANALOG OUTPUT – WIRED AS CURRENT SOURCING – SHARING SDI's 24VDC POWER SUPPLY

Attach **SDI#6 (Loop -)** to Analog input terminal of device receiving this 4-20mA signal.

Attach **SDI#7 (Loop +)** to SDI#3. (Sharing terminal with +24VDC Supply).

Attach **SDI#2 (Loop -)** to Analog Input Common. (Sometimes labeled Loop -).

### ANALOG OUTPUT – WIRED AS CURRENT SOURCING – (WITH SEPARATE 24VDC POWER SUPPLY)

Attach **SDI#6 (Loop -)** to Analog input terminal of device receiving this 4-20mA signal. (Sometimes labeled Loop +).

Attach **SDI#7 (Loop +)** to +24VDC Supply terminal.

Attach -24VDC Supply terminal to the Analog Input Common. (Sometimes labeled Loop -).

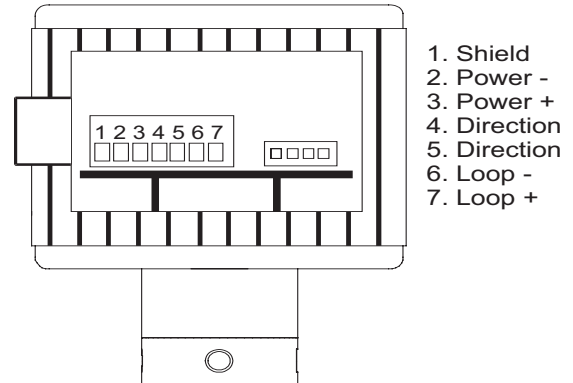

## Bi-Directional Scaled Pulse Output - Option "6" in the ordering matrix

This option provides a programmable scaled pulse output signal proportional to flow rate and a contact closure to indicate the direction of flow. All programming is accomplished as previously mentioned. The user can program the unit for pipe size, flow scale and the direction of flow. This is a six-wire option.

Attach **SDI #1 (Shield)** to Earth Ground or Power Supply Common. (This provides maximum power and signal EMI protection).

Attach **SDI #2 (Power -)** to the negative terminal of a nominal 12-24VAC/VDC Power Supply. (See data sheet for current draw and voltage limits).

Attach **SDI#3 (Power +)** to positive terminal of power supply.

Attach **SDI #4 (Pulse B -)** to the Input pulse (-) of the receiving device.

Attach **SDI #5 (Pulse B +)** to the Input pulse (+) of the receiving device.

Attach **SDI #6 (Pulse A -)** to the Input pulse (-) of the receiving device.

Attach **SDI #7 (Pulse A +)** to the Input pulse (+) of the receiving device.

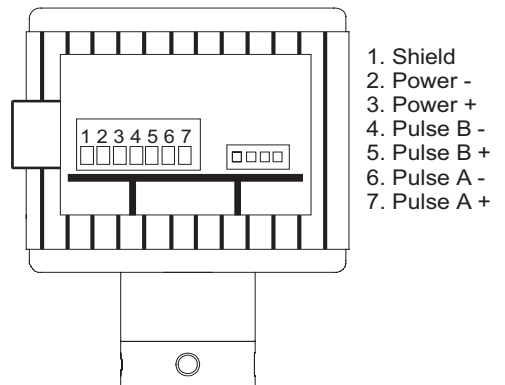

## Programming

Programming the Series SDI is accomplished by installing the Data Industrial programming software on a computer and entering data on templates of the Windows® based program.

1. Load the interface software into the computer.
2. Connect the computer to the SDI with the Data Industrial A-301 communications cable to the socket labeled “D.I.C Comm Port”, taking care to properly align the tab on the plug and socket to maintain polarity. Connect the DB9 connector of the Data Industrial A-301 communications cable to the PC com port of a PC that has the SDI software installed.
3. Connect the Series SDI Flow Sensor to a power supply.
4. Open the interface software and select the appropriate COM PORT as shown in the dialog box below.



5. Open the Parameters Screen as shown below.

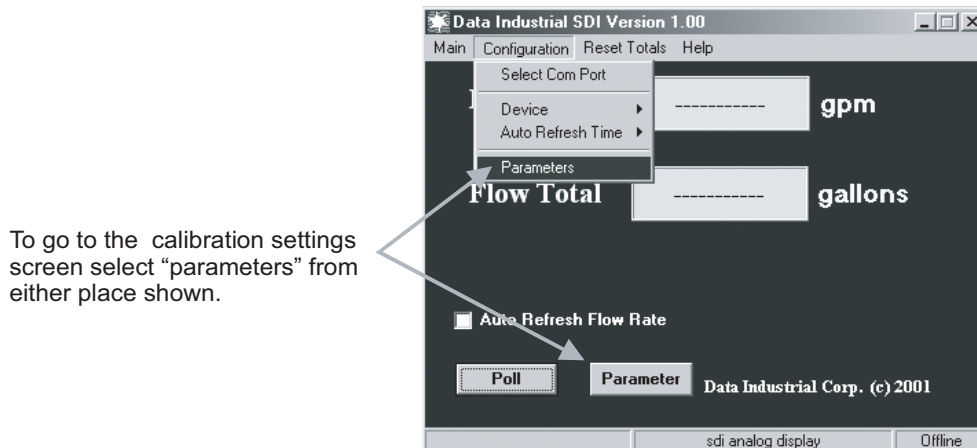

OR

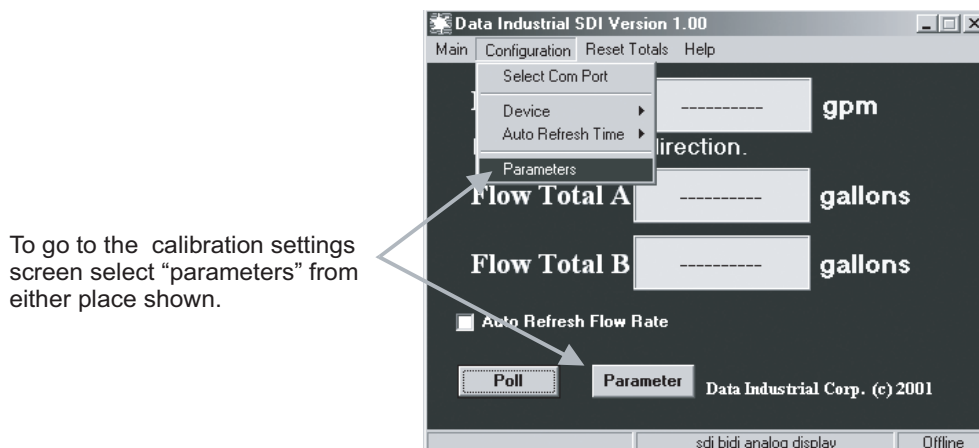

6. Program using diagram below as a reference.

## Single Direction Analog Output Models

**Step #1**  
Select rate units from the pull down values.

**Step #3**  
Select the pipe size from the pull down menu, if the pipe size is not present then custom must be selected, or check for an updated pipe.dat table on the Data Industrial web site.

**Step #5**  
Enter 4mA flow rate. This is normally zero.

**Step #7**  
For models with LCD Display Option select the desired LCD Configuration from the pull down menu. If Model has no display then skip to **Step #8**.

**Step #8**  
Press Send to transmit calibration data to the SDI Sensor.

**Step #9**  
Press to exit parameters screen and to go back to the main screen.

**Step #2**  
Select total units from the pull down values.

**See Note #1**

**Step #4**  
If custom was selected in step 3 then click the custom button and see **Note #2**.

**Step #6**  
Enter 20mA flow rate.

Press to reset all parameters back to factory defaults. Send must be pressed to send this data to the SDI.

Press to retrieve calibration data from SDI.

### Note #1

Press “details” to see “K” and “offset” numbers for the selected pipe. The “K” and “offset” are factors used to convert the sensor frequency to flow rate. They are unique to each pipe size/material.

### Note #2

Press “custom” button to enter “K” and “offset” numbers for pipe material not listed in pull down menu. The numbers may be obtained by contacting Data Industrial.

# Single Direction Scaled Pulse Output Models

## Step #1

Select rate units from the pull down values.

## Step #3

Select the pipe size from the pull down menu, if the pipe size is not present then select custom or check for an updated pipe.dat table on the Data Industrial web site.

## Step #6

For models with LCD Display Option select the desired LCD Configuration from the pull down menu. If Model has no display then skip to **Step #7**.

## Step #7

Press Send to transmit calibration data to the SDI Sensor.

## Step #2

Select total units from the pull down values.

## See Note #1.

## Step #4

If custom was selected in step 3 then click the custom button and see **Note #2**.

## Step #5

Enter the number of units per pulse and select the pulse width required.

Press to reset all parameters back to factory defaults. Send must be pressed to send this data to the SDI.

## Step #8

Press to exit parameters screen and to go back to the main screen.

Press to retrieve calibration data from SDI.

## Note #1

Press "details" to see "K" and "offset" numbers for the selected pipe. The "K" and "offset" are factors used to convert the sensor frequency to flow rate. They are unique to each pipe size/material.

## Note #2

Press "custom" button to enter "K" and "offset" numbers for pipe material not listed in pull down menu. The numbers may be obtained by contacting Data Industrial.

# Bi-Directional Analog Output Models

**Step #1**

Select rate units from the pull down values.

**Step #3**

Select the pipe size from the pull down menu, if the pipe size is not present then select custom or check for an updated pipe.dat table on the Data Industrial web site.

**Step #5**

Enter 4mA flow rate. This is normally zero.

**Step #7**

For models with LCD Display Option select the desired LCD Configuration from the pull down menu. If Model has no display then skip to **Step #10**.

**Step #9**

If the Flow direction label requires changing see Note #3.

**Step #10**

Press Send to transmit calibration data to the SDI Sensor.

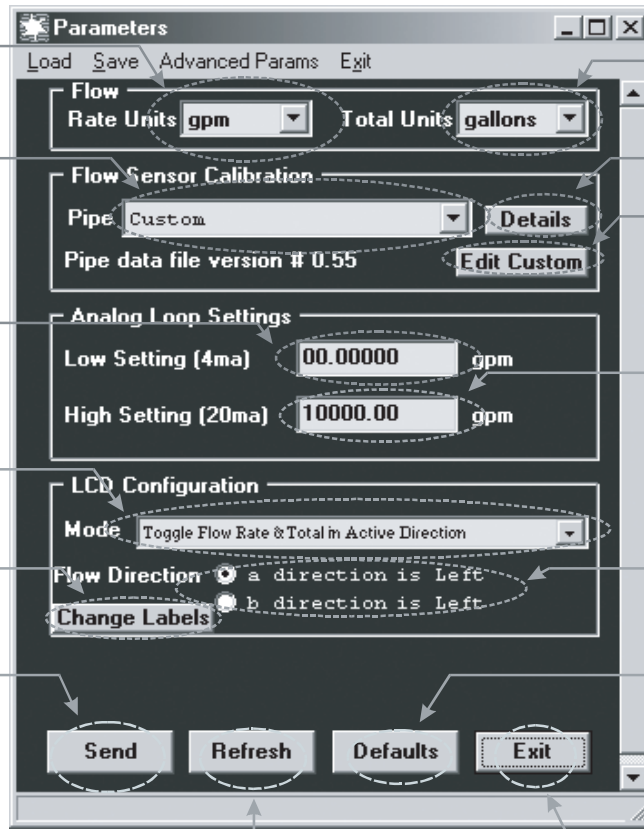

**Step #2**

Select total units from the pull down values..

See Note #1.

**Step #4**

If custom was selected in step 3 then click the custom button and see Note #2.

**Step #6**

Enter 20mA flow rate.

**Step #8**

Select Active Direction.

Press to reset all parameters back to factory defaults. Send must be pressed to send this data to the SDI.

**Step #11**

Press to exit parameters screen and to go back to the main screen.

Press to retrieve calibration data from SDI.

**Note #1**

Press “details” to see “K” and “offset” numbers for the selected pipe. The “K” and “offset” are factors used to convert the sensor frequency to flow rate. They are unique to each pipe size/material.

**Note #2**

Press “custom” button to enter “K” and “offset” numbers for pipe material not listed in pull down menu. The numbers may be obtained by contacting Data Industrial.

**Note #3**

Press “Change Label” button to change flow direction label. Enter up to 20 characters such as “From Pump”

# Bi-Directional Scaled Pulse Output Models

## Step #1

Select rate units from the pull down values.

## Step #3

Select the pipe size from the pull down menu, if the pipe size is not present then select custom or check for an updated pipe.dat table on the Data Industrial web site.

## Step #5

Select the pulse output type that is required. If raw pulse is selected skip **Step #6**.

## Step #7

For models with LCD Display Option select the desired LCD Configuration from the pull down menu. If Model has no display then skip to **Step #10**.

## Step #9

If the Flow direction label requires changing see Note #3.

## Step #10

Press Send to transmit calibration data to the SDI Sensor.

The screenshot shows a 'Parameters' window with the following sections:

- Flow:** Rate Units (gpm), Total Units (gallons)
- Flow Sensor Calibration:** Pipe (Custom), Pipe data file version # 0.55, Details, Edit Custom
- Scaled Pulse Output:** Dual Pulse, Pulse + Direction (selected), Raw Pulse; gallons/pulse (1.00), pulse width (1000)
- LCD Configuration:** Mode (Toggle Flow Rate & Total in Active Direction), Flow Direction (a direction is Left), Change Labels
- Buttons:** Send, Refresh, Defaults, Exit

## Step #2

Select total units from the pull down values.

## See Note #1.

## Step #4

If custom was selected in step 3 then click the custom button and see **Note #2**.

## Step#6

Enter the number of units per pulse and select the pulse width required.

## Step #8

Select Active Direction.

Press to reset all parameters back to factory defaults. Send must be pressed to send this data to the SDI.

## Step #11

Press to exit parameters screen and to go back to the main screen.

Press to retrieve calibration data from SDI.

## Note #1

Press "details" to see "K" and "offset" numbers for the selected pipe. The "K" and "offset" are factors used to convert the sensor frequency to flow rate. They are unique to each pipe size/material.

## Note #2

Press "custom" button to enter "K" and "offset" numbers for pipe material not listed in pull down menu. The numbers may be obtained by contacting Data Industrial.

## Note #3

Press "Change Label" button to change flow direction label. Enter up to 20 characters such as "From Pump"

## Battery Powered SDI Programming

Programming the Series SDI is accomplished by installing the Data Industrial programming software on a computer and entering data on templates of the Windows® based program.

1. Load the interface software into the computer.
2. Connect the PC to the SDI with the Data Industrial A-303 communications cable. Plug in the the RJ11 plug on the A-303 cable to the RJ11 socket on Battry Powered SDI. Connect the DB9 connector of the A-303 cable to the PC com port to a PC that has the SDI software installed.
3. Open the interface software and select the appropriate COM PORT as shown in the dialog box below.



4. Open the Parameters Screen as shown below.

To calibrate select  
“parameters” from  
either place shown.

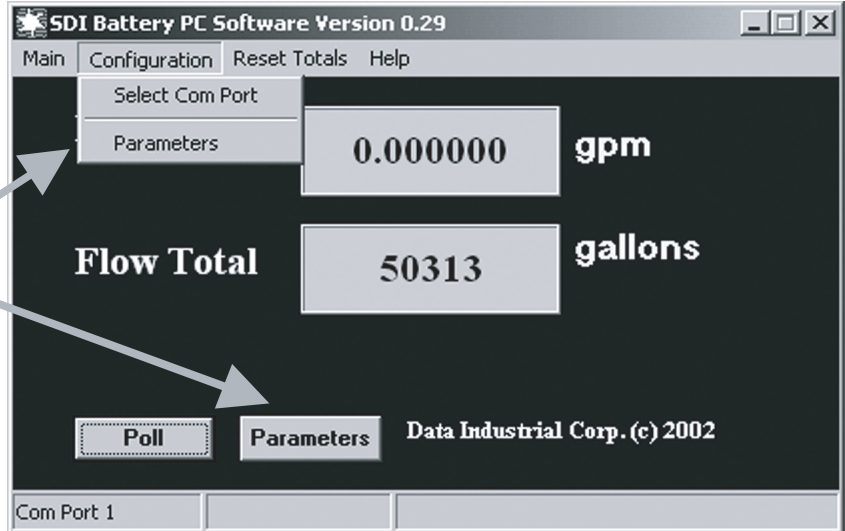

5. Program parameters using diagram below as a reference.

**Step #1**

Enter in a "K" number found in **Table B**.

**Step #2**

Enter in a "offset" number found in **Table B**.

**Step #3**

Enter in a Reference number found in **Table A**.

**Step #6**

Optional setting, Enter in the gallons/pulse and select pulse width. Skip this step if not using the Scaled pulse output

**Step #7**

Press Send to transmit calibration data to the SDI Sensor. **See Note #1**

**Step #4**

Select the desired flow rate and total units.

**Step #5**

Select the desired display readout mode.

Press to reset all parameters back to factory defaults. Send must be pressed to send this data to the SDI.

**Step #8**

Press to exit parameters screen and to go back to the main screen. **See Note #2**

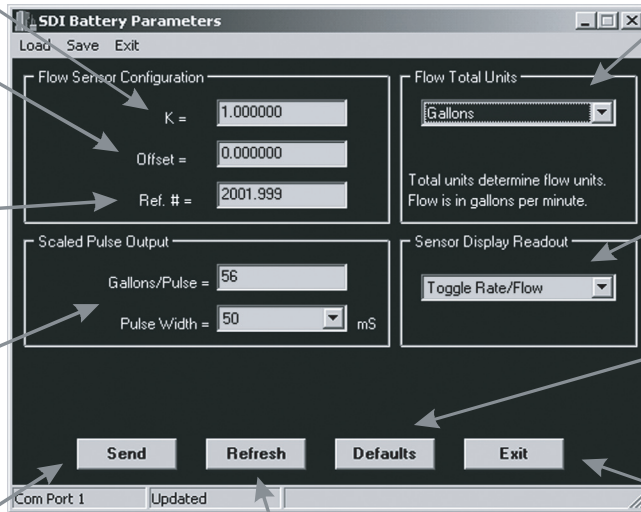

Press to retrieve calibration data from SDI.

**Note #1**

After the "send" button is pressed the unit could take up to one and a half minutes to program the Battery Powered SDI. The illustration below shows the programming process bar. When the programming process bar disappears and the status bar says "updated" the Battery Powered SDI is programmed.

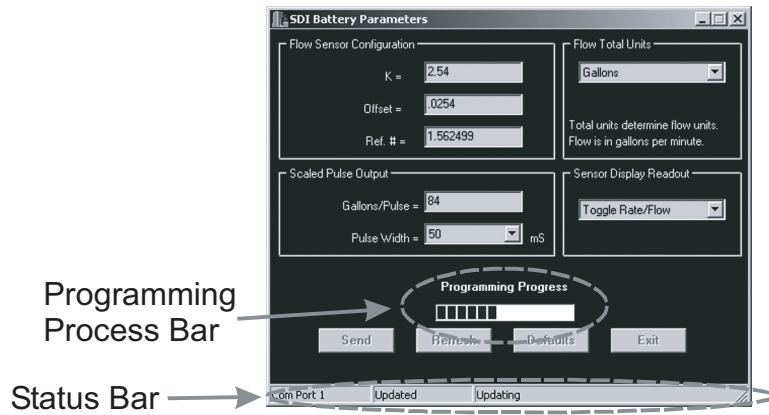

**Note #2**

After the "exit" button is pressed it takes about 10 seconds to go back to the operating display and refresh flow rate and flow total.

**Table A**  
Customer Reference Number

Pipe			Pipe Schedules					
Size	O.D.		10	10s	40	40s/Std	80	SDR21 (200)
1 1/2	1.900	Wall Insertion Depth <b>Customer Ref #</b>	.109 .58 <b>1 9/16</b>	.109 .58 <b>1 9/16</b>	.145 .54 <b>1 9/16</b>	.145 .54 <b>1 9/16</b>	.200 .49 <b>1 9/16</b>	
2	2.375	Wall Insertion Depth <b>Customer Ref #</b>	.109 .81 <b>1 13/16</b>	.109 .81 <b>1 13/16</b>	.154 .77 <b>1 13/16</b>	.154 .77 <b>1 13/16</b>	.218 .71 <b>1 13/16</b>	.113 .81 <b>1 13/16</b>
2 1/2	2.875	Wall Insertion Depth <b>Customer Ref #</b>	.120 1.05 <b>2 1/16</b>	.120 1.05 <b>2 1/16</b>	.203 .97 <b>2 1/16</b>	.203 .97 <b>2 1/16</b>	.276 .90 <b>2 1/16</b>	.137 1.04 <b>2 1/16</b>
3	3.500	Wall Insertion Depth <b>Customer Ref #</b>	.120 1.37 <b>2 3/8</b>	.120 1.37 <b>2 3/8</b>	.216 1.27 <b>2 3/8</b>	.216 1.27 <b>2 3/8</b>	.300 1.19 <b>2 3/8</b>	.167 1.32 <b>2 3/8</b>
4	4.500	Wall Insertion Depth <b>Customer Ref #</b>	.120 1.70 <b>2 11/16</b>	.120 1.70 <b>2 11/16</b>	.237 1.61 <b>2 23/32</b>	.237 1.61 <b>2 23/32</b>	.337 1.53 <b>2 3/4</b>	.214 1.63 <b>3 1/8</b>
5	5.563	Wall Insertion Depth <b>Customer Ref #</b>	.134 1.59 <b>2 5/8</b>	.134 1.59 <b>2 5/8</b>	.258 1.63 <b>2 21/32</b>	.258 1.63 <b>2 21/32</b>	.375 1.44 <b>2 11/16</b>	
6	6.625	Wall Insertion Depth <b>Customer Ref #</b>	.134 1.91 <b>2 29/32</b>	.134 1.91 <b>2 29/32</b>	.280 1.82 <b>2 31/32</b>	.280 1.82 <b>2 31/32</b>	.432 1.73 <b>3 1/32</b>	.316 1.83 <b>3 1/32</b>
8	8.625	Wall Insertion Depth <b>Customer Ref #</b>	.148 2.50 <b>3 17/32</b>	.148 2.50 <b>3 17/32</b>	.322 2.39 <b>3 19/32</b>	.322 2.39 <b>3 19/32</b>	.500 2.29 <b>3 21/32</b>	.410 2.40 <b>3 11/16</b>
10	10.750	Wall Insertion Depth <b>Customer Ref #</b>	.165 3.13 <b>4 5/32</b>	.165 3.13 <b>4 5/32</b>	.365 3.01 <b>4 1/4</b>	.365 3.01 <b>4 1/4</b>	.594 2.87 <b>4 11/32</b>	.511 2.98 <b>4 3/8</b>
12	12.750	Wall Insertion Depth <b>Customer Ref #</b>	.180 3.72 <b>4 25/32</b>	.180 3.72 <b>4 25/32</b>	.406 3.58 <b>4 7/8</b>	.375 3.60 <b>4 27/32</b>	.688 3.41 <b>5</b>	.606 3.52 <b>5</b>
14	14.000	Wall Insertion Depth <b>Customer Ref #</b>	.250 2.03 <b>3 5/32</b>	.188 2.04 <b>3 3/32</b>	.438 1.97 <b>3 9/32</b>	.375 1.99 <b>3 1/4</b>	.750 1.88 <b>3 1/2</b>	
16	16.000	Wall Insertion Depth <b>Customer Ref #</b>	.250 2.33 <b>3 7/16</b>	.188 2.34 <b>3 13/32</b>	.500 2.25 <b>3 5/8</b>	.375 2.29 <b>3 17/32</b>	.844 2.15 <b>3 7/8</b>	
18	18.000	Wall Insertion Depth <b>Customer Ref #</b>	.250 2.63 <b>3 3/4</b>	.188 2.64 <b>3 23/32</b>	.562 2.53 <b>3 31/32</b>	.375 2.59 <b>3 27/32</b>	.938 2.42 <b>4 1/4</b>	

**Table A (cont.)**  
Customer Reference Number

Pipe			Pipe Schedules				
Size	O.D.		10	10s	40	40s/Std	80
20	20.000	Wall Insertion Depth <b>Customer Ref #</b>	.250 2.93 <b>4 1/16</b>	.218 2.94 <b>4 1/32</b>	.594 2.82 <b>4 9/32</b>	.375 2.89 <b>4 1/8</b>	1.031 2.69 <b>4 19/32</b>
22	22.000	Wall Insertion Depth <b>Customer Ref #</b>	.250 3.23 <b>4 11/32</b>			.375 3.19 <b>4 7/16</b>	1.125 2.96 <b>4 31/32</b>
24	24.000	Wall Insertion Depth <b>Customer Ref #</b>	.250 3.53 <b>4 21/32</b>	.250 3.53 <b>4 21/32</b>	.688 3.39 <b>4 31/32</b>	.375 3.49 <b>4 3/4</b>	1.219 3.23 <b>5 5/16</b>
26	26.000	Wall Insertion Depth <b>Customer Ref #</b>		.312 3.81 <b>5</b>		.375 3.79 <b>5 1/32</b>	
28	28.000	Wall Insertion Depth <b>Customer Ref #</b>		.312 4.11 <b>5 9/32</b>		.375 4.09 <b>5 11/32</b>	
30	30.000	Wall Insertion Depth <b>Customer Ref #</b>	.312 4.41 <b>5 19/32</b>	.312 4.41 <b>5 19/32</b>		.375 4.39 <b>5 5/8</b>	

For sizes above 30", consult factory. Pipe O.D. & Schedule, or pipe O.D. & I.D., or pipe O.D. & wall thickness is required.

Copper Tube			Type			
Size	O.D.		K	L	M	DWV
1 1/2	1.625	Wall Insertion Depth <b>Customer Ref #</b>	.072 .48 <b>1 7/16</b>	.060 .49 <b>1 7/16</b>	.049 .50 <b>1 7/16</b>	.042 .51 <b>1 7/16</b>
2	2.125	Wall Insertion Depth <b>Customer Ref #</b>	.083 .72 <b>1 11/16</b>	.070 .73 <b>1 11/16</b>	.058 .74 <b>1 11/16</b>	.042 .76 <b>1 11/16</b>
2 1/2	2.625	Wall Insertion Depth <b>Customer Ref #</b>	.095 .95 <b>1 29/32</b>	.080 .97 <b>1 29/32</b>	.065 .98 <b>1 29/32</b>	
3	3.125	Wall Insertion Depth <b>Customer Ref #</b>	.109 1.19 <b>2 3/16</b>	.090 1.21 <b>2 3/16</b>	.072 1.23 <b>2 3/16</b>	.045 1.25 <b>2 3/16</b>
4	4.125	Wall Insertion Depth <b>Customer Ref #</b>	.134 1.54 <b>2 9/16</b>	.110 1.56 <b>2 9/16</b>	.095 1.57 <b>2 17/32</b>	.058 1.60 <b>2 17/32</b>
6	6.125	Wall Insertion Depth <b>Customer Ref #</b>	.192 1.72 <b>2 25/32</b>	.140 1.75 <b>2 3/4</b>	.122 1.76 <b>2 3/4</b>	.083 1.79 <b>2 3/4</b>

**Table A (cont.)**  
Customer Reference Number

<b>Ductile Iron</b>
---------------------

Because of the variety of iron pipe classes, sizes, and wall thicknesses, consult factory for customer reference number. Pipe O.D. & Schedule, or pipe O.D. & I.D., or pipe O.D. & wall thickness is required.

<b>PVC AWWA C900</b>			
Size	O.D.		CL100
4	4.800	Wall Insertion Depth <b>Customer Ref #</b>	.192 1.77 <b>2 27/32</b>
6	6.900	Wall Insertion Depth <b>Customer Ref #</b>	.276 1.90 <b>3 1/16</b>
8	9.050	Wall Insertion Depth <b>Customer Ref #</b>	.362 2.50 <b>3 23/32</b>
10	11.100	Wall Insertion Depth <b>Customer Ref #</b>	.444 3.06 <b>4 3/8</b>
12	13.200	Wall Insertion Depth <b>Customer Ref #</b>	.528 3.64 <b>5 1/16</b>

For other types of pipe not listed above, consult factory. Pipe O.D. & Schedule, or pipe O.D. & I.D., or pipe O.D. & wall thickness is required.

**Table B**  
k & Offset

Pipe			Pipe Schedules					
Size	O.D.		10	10s	40	40s/Std	80	SDR21 (200)
1 1/2	1.900	K Offset			0.297315 0.859353	0.297315 0.859353	0.244927 0.859353	
2	2.375	K Offset	0.801632 1.813024	0.801632 1.813024	0.498124 1.523850	0.498124 1.523850		
2 1/2	2.875	K Offset	0.801632 1.813024	0.801632 1.813024	0.699870 1.111784	0.699870 1.111784	0.654225 1.307587	
3	3.500	K Offset	1.317775 1.756472	1.317775 1.756472	1.169137 1.609184	1.169137 1.609184	1.070953 1.307587	1.212446 1.056965
3 1/2	3.500	K Offset			1.612333 1.609184	1.612333 1.609184		
4	4.500	K Offset	2.110168 4.142096	2.110168 4.142096	1.872713 4.142096	1.872713 4.142096	1.964629 1.307587	
5	5.563	K Offset			3.251260 2.093849	3.251260 2.093849		
6	6.625	K Offset	5.144059 3.295640	5.144059 3.295640	4.642584 3.295640	4.642584 3.295640	4.237085 2.093849	
8	8.625	K Offset			8.730561 2.793790	8.730561 2.793790		
10	10.750	K Offset			13.737621 2.937799	13.737621 2.937799	12.476283 2.937799	
12	12.750	K Offset			19.830912 2.768877	20.041272 2.768877	17.796906 2.937799	
14	14.000	K Offset			24.238528 2.768877	24.702144 2.768877		
16	16.000	K Offset			31.728175 2.768877	32.804463 2.768877	28.663241 2.768877	
18	18.000	K Offset			41.579656 3.715358	43.462537 3.715358	37.706693 3.715358	
20	20.000	K Offset			51.751173 3.715358		46.771847 3.715358	
22	22.000	K Offset						
24	24.000	K Offset			74.0284944 3.155189	78.201801 3.155189	67.789784 3.715358	
26	26.000	K Offset						
28	28.000	K Offset		123.735118 3.155189				
30	30.000	K Offset				123.735118 3.155189		

For sizes above 30", consult factory. Pipe O.D. & Schedule, or pipe O.D. & I.D., or pipe O.D. & wall thickness is required.

**Table B (cont.)**

Copper Tube			Type			
Size	O.D.		K	L	M	DWV
1 1/2	1.625	K Offset		0.277993 0.063685		
2	2.125	K Offset		0.509285 -0.043054		
2 1/2	2.625	K Offset		0.784450 -0.126200		
3	3.125	K Offset		1.177171 0.198965		
4	4.125	K Offset		1.750507 4.142096		
5	5.125	K Offset		3.587835 0.198965		
6	6.125	K Offset	5.041780 0.198965	4.298570 3.295640		

**Ductile Iron**

Because of the variety of iron pipe classes, sizes, and wall thicknesses, consult factory for customer reference number. Pipe O.D. & Schedule, or pipe O.D. & I.D., or pipe O.D. & wall thickness is required.

PVC Municipal C900			Schedules
Size	O.D.		100
4	4.800	K Offset	
6	6.900	K Offset	
8	9.050	K Offset	
10	11.100	K Offset	
12	13.200	K Offset	

For other types of pipe not listed above, consult factory. Pipe O.D. & Schedule, or pipe O.D. & I.D., or pipe O.D. & wall thickness is required.

Blank boxes indicate no data at time of printing.

## SPECIFICATIONS

### Wetted Materials

#### Sensor stem, mounting adapter, isolation valve, and nipple:

- 316 Stainless steel

#### Sensor Tip:

- polyphenylene sulfide (PPS)

#### O-rings,bearings,shaft:

- see ordering matrix

#### Maximum Temperature Ratings:

##### Fluid measured

- 300° F (135°C) continuous service

#### Operating temperature: Electronics:

- 150°F (65°C)

#### Operating Temperature: LCD:

- 150°F (65°C)

#### Maximum Pressure Rating:

- 1000 psi @ 100°F
- 900 psi @ 200°F
- 750 psi @ 300°F

#### Recommended Design Flow Range:

- 0.33 to 20 ft/sec
- Initial flow detection below .25 ft/sec

#### Pressure Drop:

- 0.5 psi or less @ 10 ft/sec for all pipe sizes 1.5" dia and up.

#### Accuracy:

- Standard calibration NIST traceable to +/- 1% of rate
- Custom wet calibration NIST traceable to +/- 0.5% of rate

### Straight Pipe Requirement:

- install sensor in straight pipe section with a minimum distance of 10 diameters upstream and 5 diameters downstream to any bend, transition, or obstruction.

### Repeatability:

+/- 0.5%

### Enclosure:

- Polypropylene with Viton® sealed acrylic cover. Meets NEMA 4X specifications

### Wire Connections:

- all wire connections are made to removable headers with screw type terminals within the electronics housing, 1/2" conduit thread provided

### Programming:

- all programmable models utilize Data Industrial A-301 connector cable and SDI Series software

### Display: (optional)

- 8 character, 3/8" LCD
- STN (Super twisted Nematic) display
- annunciators for:
  - rate, total, input, output flow direction for Bi-directional models

### Accessories

- ASDI Programming Kit
- A1027 Hot Tap Adapter Nipple

	uni-directional			bi-directional	
	raw pulse option 0	analog loop option 1	scaled pulse option 2	analog loop option 5	scaled pulse option 6
Number of wire connections	2	2	4	6	6
Pulse Units					
Operating Voltage	8-35 VDC	N/A	12-30 VAC 12-35 VDC	12-30 VAC 12-35 VDC	12-30 VAC 12-35 VDC
Overvoltage protection	30 VAC ±40 VDC	±40 VDC	30 VAC ±40 VDC	30 VAC ±40 VDC	30 VAC ±40 VDC
Quiescent Current Draw @12VDC or 24VAC	330uA TYP	Software controlled current of 3.5-20.5mA	< 2mA	< 5.0 mA	< 5.0 mA
Short Circuit Current	50mA TYP	N/A	> 100 mA	for direction > 100 mA	> 100 mA
Output Frequency	800 Hz max	N/A	scaled by customer	N/A	scaled by customer
Output Pulse Width	5 mS below 100 Hz	N/A	adjustable 50mS to 5.0 second in 50 mS increments	N/A	adjustable 50mS to 5.0 second in 50 mS increments
Output Isolation	N/A	N/A	Opto-Isolated	Opto-Isolated	Opto-Isolated
Analog Units					
Operating Voltage	N/A	8-35 VDC	N/A	8-35 VDC	N/A
Output Response Time	N/A	varies with programmable filter	N/A	varies with programmable filter	N/A

*(This page intentionally left blank.)*

*(This page intentionally left blank.)*

Viton® is a registered trademark of DuPont-Dow Elastomers.  
Torlon® is a registered trademark of Amoco Performance Products.  
Windows® is a registered trademark of Microsoft Corporation.  
Hastelloy® is a registered trademark of Haynes Corporation.



Copyright © Badger Meter, Inc. 2009. All rights reserved.

Due to continuous research, product improvements and enhancements, Badger Meter reserves the right to change product or system specifications without notice, except to the extent an outstanding contractual obligation exists.



**BadgerMeter, Inc.**